

## Horn

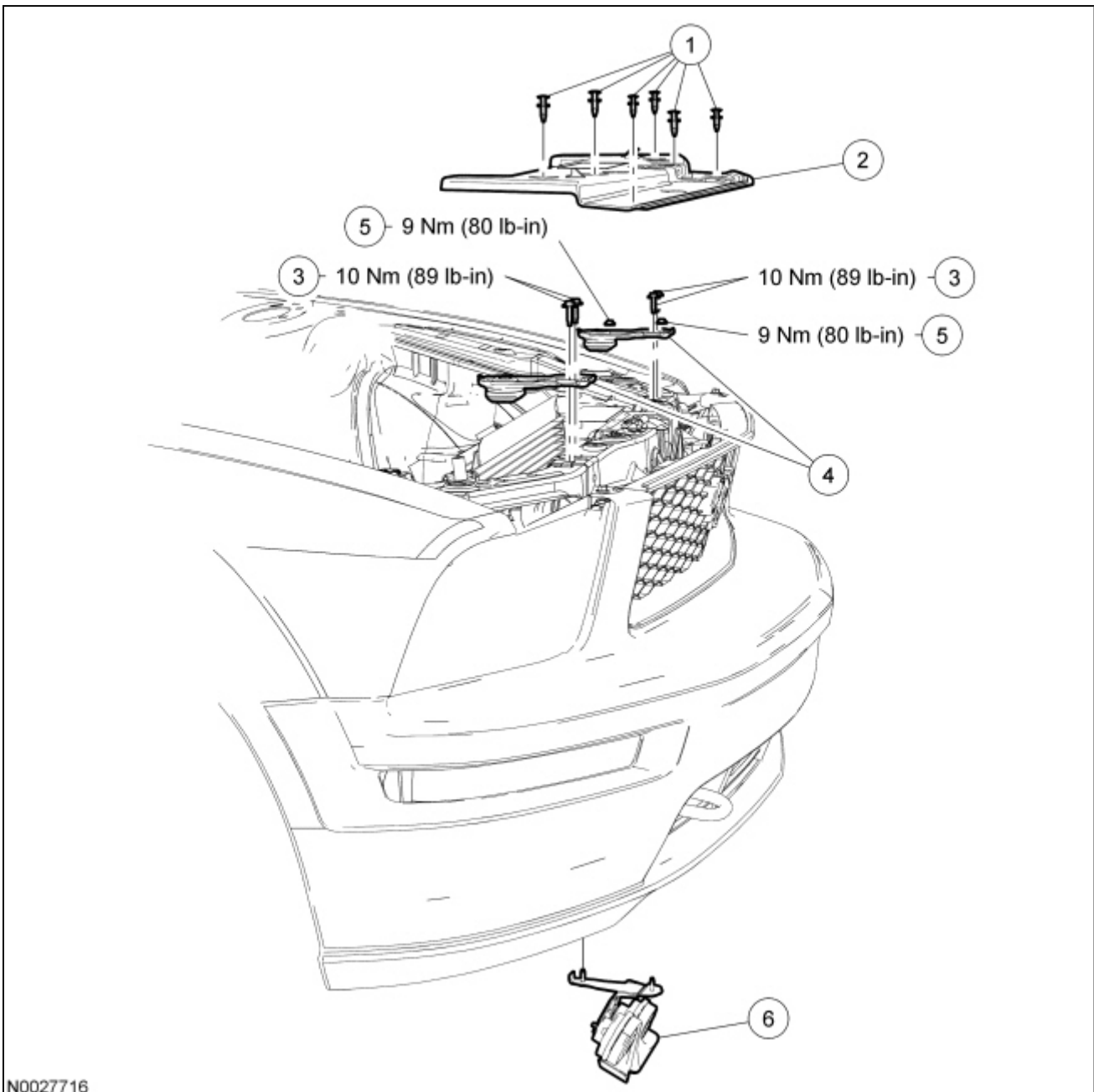

N0027716

Item	Part Number	Description
1	W705436	Upper radiator sight shield pin-type retainers (6 required)
2	8C291	Upper radiator sight shield
3	W505424	Radiator support bracket bolts (4 required)
4	8226	Radiator support brackets (2 required)
5	W709450	Horn bracket nuts (2 required)
6	13832	Horn

### Removal and Installation

1. With the vehicle in NEUTRAL, position it on a hoist. For additional information, refer to [Section 100-02](#).
  2. Remove the 6 pin-type retainers and the upper radiator sight shield.
  3. Remove the 4 bolts and the 2 radiator support brackets.
    - To install, tighten to 10 Nm (89 lb-in).
  4. Position the top of the radiator and condenser assembly toward the engine.
  5. Remove the 2 horn bracket nuts.
    - To install, tighten to 9 Nm (80 lb-in).
  6. If equipped, remove the 6 front bumper cover-to-valance panel screws and remove the valance panel.
  7. Disconnect the electrical connector and remove the horn.
  8. To install, reverse the removal procedure.
-